

POWER UNIT 05 - WIRING HARNESS

NOTE: WHERE THERE IS NO LOOM, SECURE WIRES WITH ELECTRICAL TAPE OR TIESTRAP.

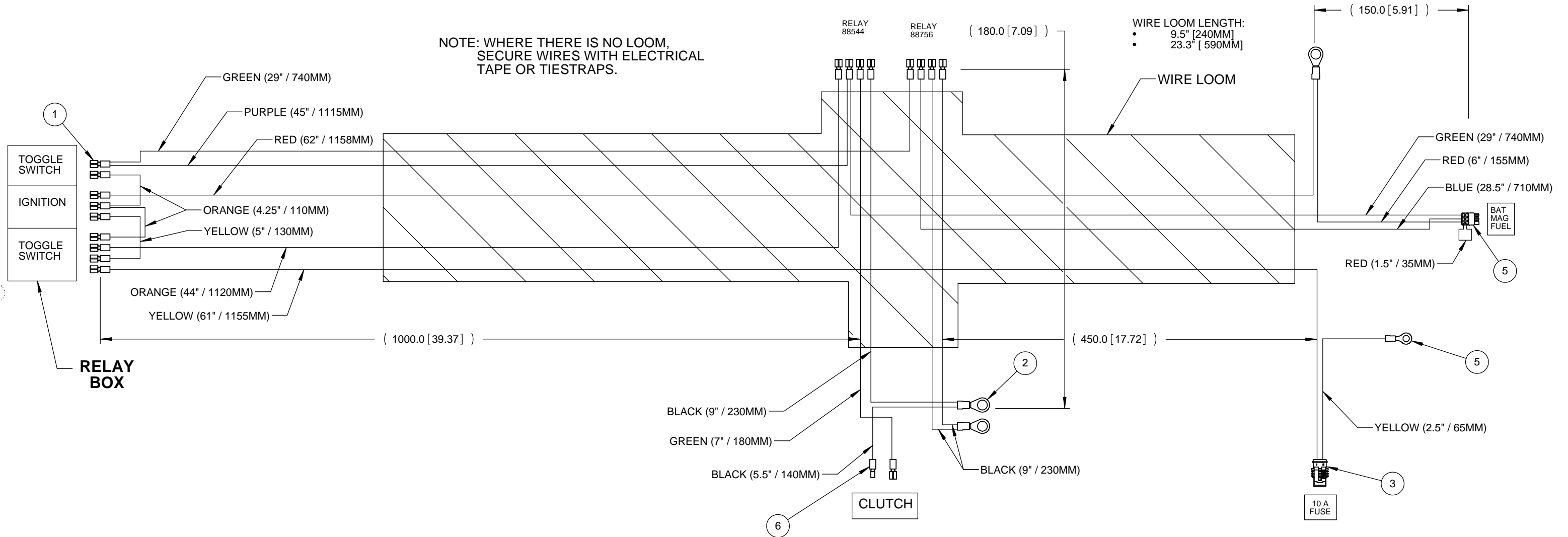

3RD ANGLE PROJECTION		TOLERANCES (UNLESS OTHERWISE SPECIFIED) DIMENSIONS ARE IN MILLIMETERS.		Quadivator ^{INC}		88723	
PROPRIETARY AND CONFIDENTIAL THE INFORMATION CONTAINED IN THIS DRAWING IS PROPRIETARY AND CONFIDENTIAL. ANY REPRODUCTION IN WHOLE OR IN PART WITHOUT WRITTEN PERMISSION IS EXPRESSLY PROHIBITED. DO NOT SCALE DRAWING		LINEAR X. ± 2.0 .X ± 1.0 .XX ± 0.5 BEND RADIUS = MAT'L THICKNESS SURFACE ROUGHNESS: 6.3					
NEXT ASSY. -		QTY. PER ASSY. -		PART DESCRIPTION WIRING HARNESS - 05 POWER UNIT			
PART NO. 88723		SIMILAR PART 88723		RAW MATERIAL: See Bill of Materials			
DESIGNED JC		DRAWN GK		RAW MAT NUMBER: SEE B.O.M.			
0		842		SCALE 1:2		WEIGHT (LB.) 12.1	
1		07/18/2006		SHEET 1 of 1		REVISION 0	
ECO		DATE		APPR			

ITEM	88723/QTY.	PART	DESCRIPTION
1	18	CON - 300	1/4" FEMALE SPADE CONNECTOR
2	3	Default	TERMINAL - RING TONGUE 1/2"
3	1	CON - 302	PED 15 FUSE HOLDER
4	1	Default	TERMINAL, RING TONGUE 1/4"
5	1	CON - 304	6 PIN CONNECTOR
6	1	CON 305	1/4" MALE SPADE CONNECTOR